

Hohlraum- dübel HRM



Vorteile



- Geeignet für Befestigungen auf Plattenbaustoffen, z.B. Gipskarton- oder Spanplatten, aber auch z. B. in Hohldecken
- Nach erfolgter Installation spreizt sich der Dübel großflächig ab, dies sorgt für hohe Haltewerte
- Montage mit Setzzange MZA 100, Akkuschauber und Schraubendreher möglich; empfohlen wird die Setzzange zur kontrollierten und schnellen Montage
- Nicht brennbar nach DIN EN 13501-1, Klasse A1

Geeignete Baustoffe

Sehr gut geeignet



- Hohldecken
- Hohlwände
- Gipskarton/-faserplatten
- Spanplatten

Bedingt geeignet

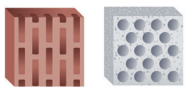

- Lochsteine mit großen Kammern

Montage

Montage mit Montagezange [empfohlen]

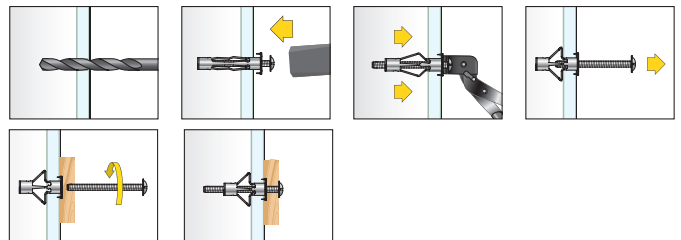

Montage ohne Montagezange

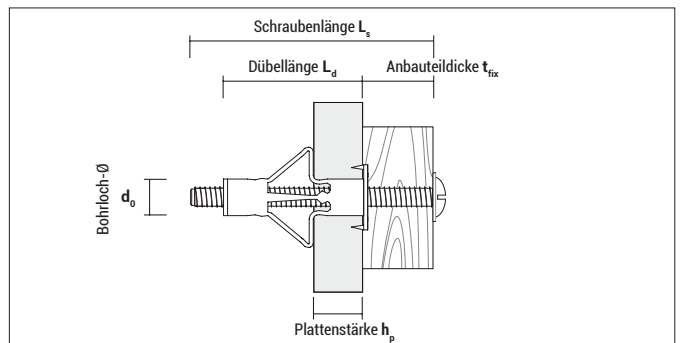
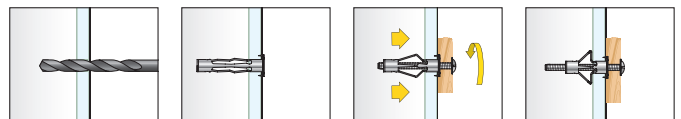

Montagezange MZA 100 für HRM



Typ	Art.-Nr.	€/Stück	[Stück]	[Stück]
MZA 100	9MZA00		1	-

Hohlraumdübel HRM



HRM

Typ	Art.-Nr.	d ₀ [mm]	h _p min-max [mm]	Gewinde	L _s [mm]	L _d [mm]	t _{fix} ¹⁾ [mm]	€ / 100 Stück	[Stück]	[Stück]
Kleinpäckung (Fensterpackung)	HRM 4x20	9420HRM50	8	3 - 18	M4	52	46	43 - 28	50	1.350
	HRM 4x24	9424HRM50	8	18 - 24	M4	58	52	34 - 28	50	1.350
	HRM 4x38	9438HRM50	8	32 - 38	M4	72	66	34 - 28	50	1.350
	HRM 5x16	9516HRM50	11	3 - 16	M5	58	52	49 - 36	50	1.350
	HRM 5x32	9532HRM25	11	14 - 32	M5	71	65	51 - 33	25	675
	HRM 5x45	9545HRM25	11	32 - 45	M5	88	80	48 - 35	25	675
	HRM 6x16	9616HRM25	13	3 - 16	M6	58	52	49 - 36	25	675
	HRM 6x32	9632HRM25	13	14 - 32	M6	71	65	51 - 33	25	675
	HRM 6x45	9645HRM25	13	32 - 45	M6	88	80	48 - 35	25	675
	HRM 8x16*	9816HRM25	13	3 - 16	M8	61	53	50 - 37	25	675
HRM 8x32*	9832HRM20	13	16 - 32	M8	73	66	50 - 34	20	360	
Großpackung	HRM 4x20	9420HRM	8	3 - 18	M4	52	46	43 - 28	100	1.000
	HRM 4x24	9424HRM	8	18 - 24	M4	58	52	34 - 28	100	1.000
	HRM 4x38	9438HRM	8	32 - 38	M4	72	66	34 - 28	100	1.000
	HRM 5x16	9516HRM	11	3 - 16	M5	58	52	49 - 36	100	500
	HRM 5x32	9532HRM	11	14 - 32	M5	71	65	51 - 33	100	500
	HRM 5x45	9545HRM	11	32 - 45	M5	88	80	48 - 35	100	900
	HRM 6x16	9616HRM	13	3 - 16	M6	58	52	49 - 36	100	500
	HRM 6x32	9632HRM	13	14 - 32	M6	71	65	51 - 33	100	900
	HRM 6x45	9645HRM	13	32 - 45	M6	88	80	48 - 35	100	600
	HRM 8x16*	9816HRM	13	3 - 16	M8	61	53	50 - 37	100	300
HRM 8x32*	9832HRM	13	16 - 32	M8	73	66	50 - 34	100	300	

* Sechskantschraube, SW 13

¹⁾ Bitte beachten: Anbauteildicke t_{ix} ist abhängig von der Plattenstärke h_p



Blister HRM



Typ	Art.-Nr.	d ₀ [mm]	h _p min-max [mm]	Gewinde	L _s [mm]	L _d [mm]	Schraubentyp	€ / Blister	[Stück]	[Blister]
4x20	5420HRM5	8	3 - 18	M4	52	46			5	10
4x24	5424HRM5	8	18 - 24	M4	58	52			5	10
5x16	5516HRM5	11	3 - 16	M5	58	52			5	10
5x16 RH	5516HRMRH4	11	3 - 16	M5	58	52			4	10
5x16 WH	5516HRMWH4	11	3 - 16	M5	58	52			4	10
5x32	5532HRM5	11	14 - 32	M5	71	65			5	10
5x32 RH	5532HRMRH4	11	14 - 32	M5	71	65			4	10
5x32 WH	5532HRMWH4	11	14 - 32	M5	71	65			4	10
6x16	5616HRM5	13	3 - 16	M6	58	52			5	10
6x32	5632HRM5	13	14 - 32	M6	71	65			5	10

Tragfähigkeiten F_{empf}

Typ	Sperrholz		Gipskarton			
	6 mm F _{empf} [kN]	16 mm F _{empf} [kN]	h _p = 9,5 mm F _{empf} [kN]	h _p = 12,5 mm F _{empf} [kN]	h _p = 2 x 12,5 mm F _{empf} [kN]	h _p = 3 x 12,5 mm F _{empf} [kN]
HRM 4x20	0,15	0,25	0,15	0,15	-	-
HRM 4x24	-	-	-	-	0,15	-
HRM 4x38	-	-	-	-	-	0,25
HRM 5x16	0,20	0,25	0,20	0,20	-	-
HRM 5x32	-	-	-	-	0,35	-
HRM 5x45	-	-	-	-	-	0,35
HRM 6x16	0,25	0,30	0,25	0,25	-	-
HRM 6x32	-	-	-	-	0,35	-
HRM 6x45	-	-	-	-	-	0,40
HRM 8x16	0,30	0,40	0,25	0,25	-	-
HRM 8x32	-	-	-	-	0,40	-