

# Metal-Befestigungsclip

## F & DF

### Vorteile



- Zwei Versteifungsrippen für eine erhöhte Stabilität
- Bohrung mit  $\varnothing 6,5$  mm zur Dübelmontage
- Galvanisch verzinkt
- Montierbar mit allen gängigen Dübeln, Nageldübel NP, Betonschraube BTS 4, BTS 5, Deckenanker DA usw.



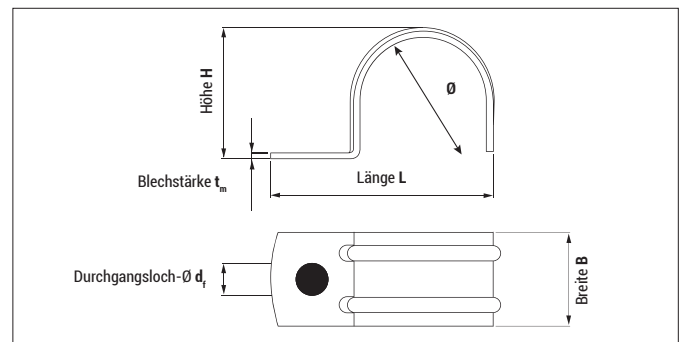

### Montage



## Metall-Befestigungsclip F & DF





### F Clip

Typ	Art.-Nr.	Durchmesser Ø [mm]	Länge L [mm]	Breite B [mm]	Höhe H [mm]	Durchgangsloch Ø d <sub>f</sub> [mm]	Blechstärke t <sub>m</sub> [mm]	€/100 Stück	 [Stück]	 [Stück]
F Clip 6	96F	6	21,8	12	7,4	6,5	0,8		100	4.000
F Clip 8	98F	8	23,8	12	9,4	6,5	0,8		100	4.000
F Clip 10	910F	10	25,8	12	11,4	6,5	0,8		100	1.800
F Clip 12	912F	12	27,8	12	13,4	6,5	0,8		100	1.800
F Clip 14	914F	14	31,5	15	15,6	6,5	1		100	1.800
F Clip 16	916F	16	33,5	15	17,6	6,5	1		100	1.800
F Clip 18	918F	18	35,5	15	19,6	6,5	1		100	900
F Clip 20	920F	20	38,7	18	21,9	6,5	1,2		100	900
F Clip 22	922F	22	40,7	18	23,9	6,5	1,2		100	900
F Clip 25	925F	25	43,7	18	26,9	6,5	1,2		100	900
F Clip 28	928F	28	46,7	18	29,9	6,5	1,2		100	900
F Clip 32	932F	32	53,5	20	34,3	6,5	1,5		100	600
F Clip 40	940F	40	61,5	20	42,3	6,5	1,5		100	450
F Clip 50	950F	50	71,5	20	52,3	6,5	1,5		100	450



### DF Clip

Typ	Art.-Nr.	Durchmesser Ø [mm]	Länge L [mm]	Breite B [mm]	Höhe H [mm]	Durchgangsloch Ø d <sub>f</sub> [mm]	Blechstärke t <sub>m</sub> [mm]	€/100 Stück	 [Stück]	 [Stück]
DF Clip 6	96DF	6	38,5	12	5	6,5	1		100	1.800
DF Clip 8	98DF	8	42,5	12	7	6,5	1		100	1.800
DF Clip 10	910DF	10	46,0	12	9	6,5	1		100	900
DF Clip 12	912DF	12	51,0	12	11	6,5	1		100	900

### Technische Information F-Clip

Ø [mm]	empfohlene Lasten [kg]	Ø Rohre		
		Kunststoff [mm]	Kupfer [mm]	Stahl [Zoll]
F Clip 6	12	-	6	-
F Clip 8	12	-	8	-
F Clip 10	12	-	10	1/8"
F Clip 12	12	-	12	-
F Clip 14	15	-	-	1/4"
F Clip 16	15	16	-	-
F Clip 18	15	-	18	3/8"
F Clip 20	18	20	-	-
F Clip 22	18	-	22	1/2"
F Clip 25	18	25	-	-
F Clip 28	18	-	28	-
F Clip 32	20	32	-	-
F Clip 40	20	40	-	-
F Clip 50	20	50	-	-

### Technische Information DF-Clip

Ø [mm]	empfohlene Lasten [kg]	Ø Rohre		
		Kunststoff [mm]	Kupfer [mm]	Stahl [Zoll]
DF Clip 6	7	-	6	-
DF Clip 8	7	-	8	-
DF Clip 10	7	-	10	1/8"
DF Clip 12	7	-	12	-